

GB-75

Great Basin™ High Efficiency Grease Interceptor Technical Data

Submittal | Special Precautions | Specifications | Installation | Application Specific Details

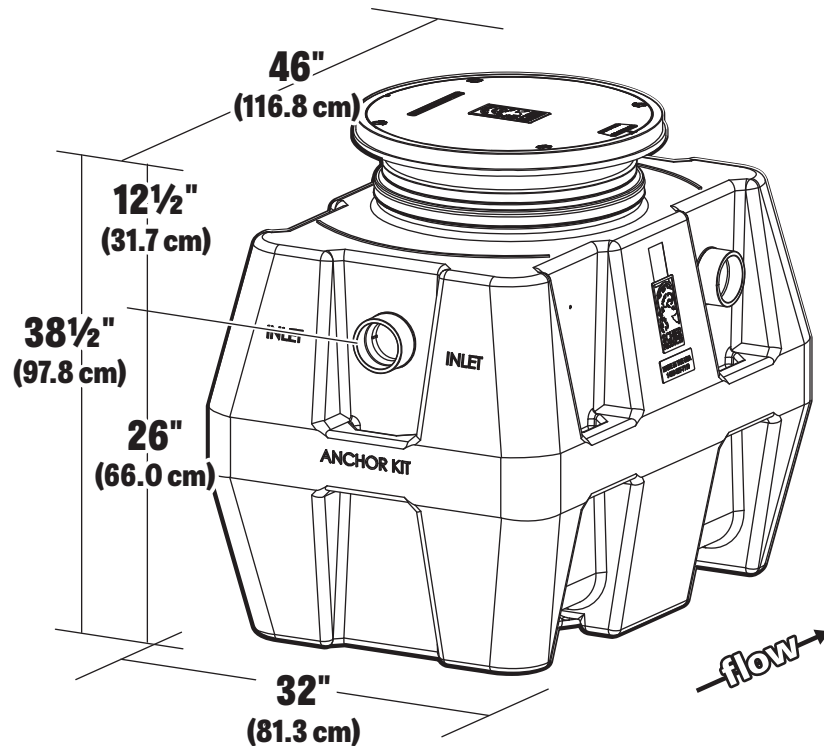

SUBMITTAL

STANDARD: 4" plain end inlet/outlet | Capacities - Liquid: 125 gal. (472.5 L); Grease: 616 lbs. (279.4 kg) (86.0 gal./325 L); Solids: 19.2 gal. (72.5 L); Highway traffic load rated, bolted, gas/water tight composite cover. (16,000 lbs.)

OPTIONS:

- 4" Male Thread Inlet/Outlet
- 6" Plain End Inlet/Outlet
- 6" Male Thread Inlet/Outlet (stainless steel)
- Pedestrian Rated Covers - 2,000 lbs.
- H2O Load Rated Pickable Cast Iron Covers
- Integral Membrane Clamping Collar Kit
- Pumpout Port (Medium)
- High Water Anchor Kit

TeleGlide Risers

- SR24 5" - 23"
- LR24 >23" - 38"
- SR24 (x2) >38" - 43"
- SR24 + LR24 >43" - 58"
- LR24 (x2) >58" - 72"

APPROVAL:

Signature:
Date:
Company:
Specifying Engineer:
Engineering Firm:



SCHIER
LIFETIME GUARANTEED
GREASE INTERCEPTORS

MODEL NUMBER:
GB-75

DESCRIPTION: Polyethylene Grease Interceptor
75 GPM - 125 gallon capacity

PART #: 4045-001-XX

DWG BY: B. Karrer

DATE: 10/08/2015

REV: 4 10/13/2017

ECO:



SPECIAL PRECAUTIONS

For All Schier Grease Interceptor Installations

Installation Instructions

Installation instructions and additional components are located inside the interceptor. Read all instructions prior to installation. This interceptor is intended to be installed by a licensed plumber in conformance with all local codes.

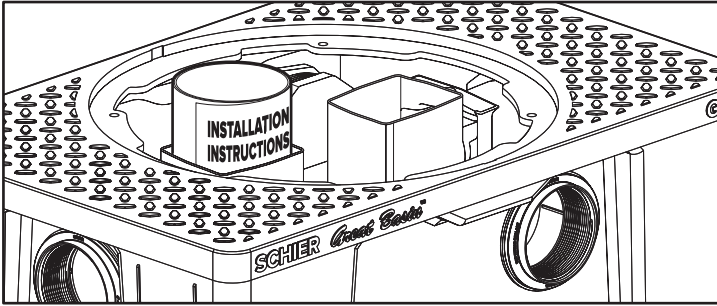

When Installing Interceptor Inside

If your dishwashing sink(s) discharges into a floor drain/sink (drain), you must regulate the flow into the drain to avoid an overflow of water onto the kitchen floor. This can be done by installing a valve or flow restriction cap on the sink piping that discharges into the drain. See drawing below for guidance. For detailed guidance on indirect connections, go to: http://webtools.schierproducts.com/Technical_Data/Indirect_Connections.pdf

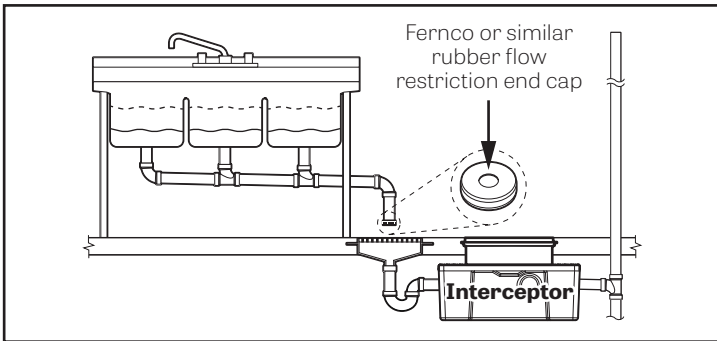

Hydrostatic Slabs (or Pressure Slabs)

When installed under a hydrostatic slab (slab designed to withstand upward lift, usually caused by hydrostatic pressure) interceptor must be enclosed in a watertight concrete vault. Failure to follow this guidance voids your warranty.

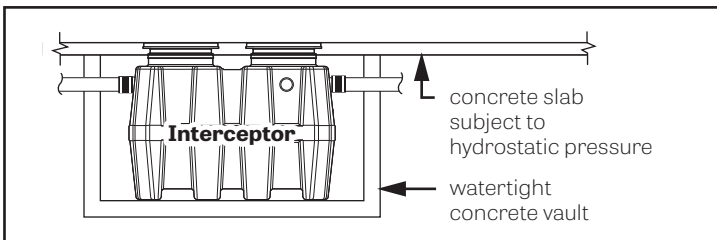

High Temperature Kitchen Water

If water is entering the interceptor at excessive temperature (over 140° F), a drain water tempering valve (DTV) must be installed. Most state and local plumbing codes prohibit water above 140° F being discharged into the sanitary sewer. Water above 140° F will weaken or deform PVC Schedule 40 pipe, poly drainage fixtures like interceptors and erode the coating of cast iron (leading to eventual failure). Failure to follow this guidance voids your warranty.

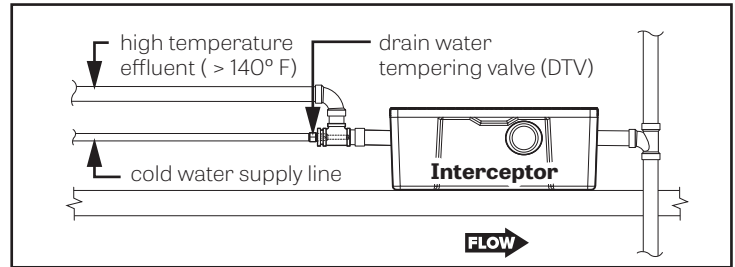

High Water Table Installations

Interceptors and risers are not designed to withstand water table height in excess of the top of the unit when buried (see figure). If it is possible for this to occur, install the interceptor and risers in a water-tight concrete vault or backfill with concrete or flowable fill (wet concrete and flowable backfill should be poured in stages to avoid crushing the interceptor). At risk areas include but are not limited to tidal surge areas, floodplains and areas that receive storm water. Failure to follow this guidance voids your warranty.

Models GB-50, GB-75, and GB-250 that are direct buried in high water table scenarios must be installed with model AK1 anchor kit or warranty is void.

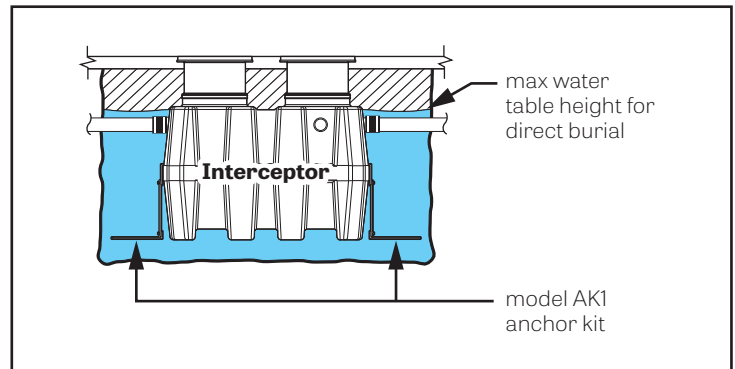

SCHIER
LIFETIME GUARANTEED
GREASE INTERCEPTORS

MODEL NUMBER:
GB-75

DESCRIPTION: Polyethylene Grease Interceptor
75 GPM - 125 gallon capacity

PART #: 4045-001-XX

DWG BY: B. Karrer

DATE: 10/08/2015

REV: 4 10/13/2017

ECO:

SPECIFICATIONS

NOTES

- 4" plain end inlet/outlet
- Unit weight - w/composite cover: 130 lbs.; w/cast iron cover: 210 lbs. (For wet weight add 1041 lbs)
- Maximum operating temperature: 140° F continuous
- Capacities - Liquid: 125 gal.; Grease: 616 lbs. (86 gal.); Solids: 19.2 gal.
- Built-in Flow control.
- For gravity drainage applications only.
- Do not use for pressure applications.
- Cover placement allows full access to tank for proper maintenance.
- Vent not required unless per local code.
- Engineered inlet and outlet diffusers are removable to inspect/clean piping.
- Integral air relief / Anti-siphon.

DIFFUSION FLOW TECHNOLOGY

The inlet diffuser splits influent into three paths, creating laminar flow and utilizing the entire liquid volume of the tank for efficient grease separation. The calibrated openings greatly reduce effluent turbulence. The effluent enters the main chamber without disturbing the existing grease or sediment layers.

The integral air relief / anti-siphon in the top of the outlet diffuser allows pressure stabilization within the unit during operation. The bottom of the outlet diffuser allows only effluent which is free of grease to exit the tank. It can easily be attached to any of the three outlets provided to ease jobsite piping layouts.

ENGINEER SPECIFICATION GUIDE

Schier Great Basin™ grease interceptor model # GB-75 shall be lifetime guaranteed and made in USA of seamless, rotationally-molded polyethylene. Interceptor shall be furnished for above or below grade installation. Interceptor shall be certified to ASME A112.14.3 (type C) and CSA B481.1, with field adjustable riser system, built-in flow control, built-in test caps and three outlet options. Interceptor flow rate shall be 75 GPM. Interceptor grease capacity shall be 616 lbs. Cover shall provide water/gas-tight seal and have minimum 16,000 lbs. load capacity.

CERTIFIED PERFORMANCE

Great Basin hydromechanical grease interceptors are third party performance-tested and listed by IAPMO to ASME #A112.14.3 and CSA B481.1 grease interceptor standards and greatly exceed requirements for grease separation and storage. They are compliant to the Uniform Plumbing Code and the International Plumbing Code.

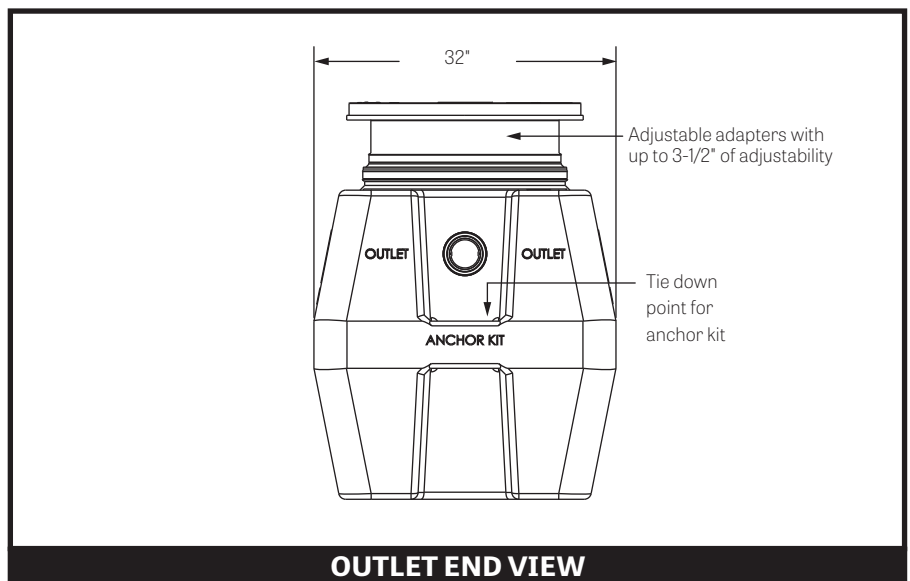
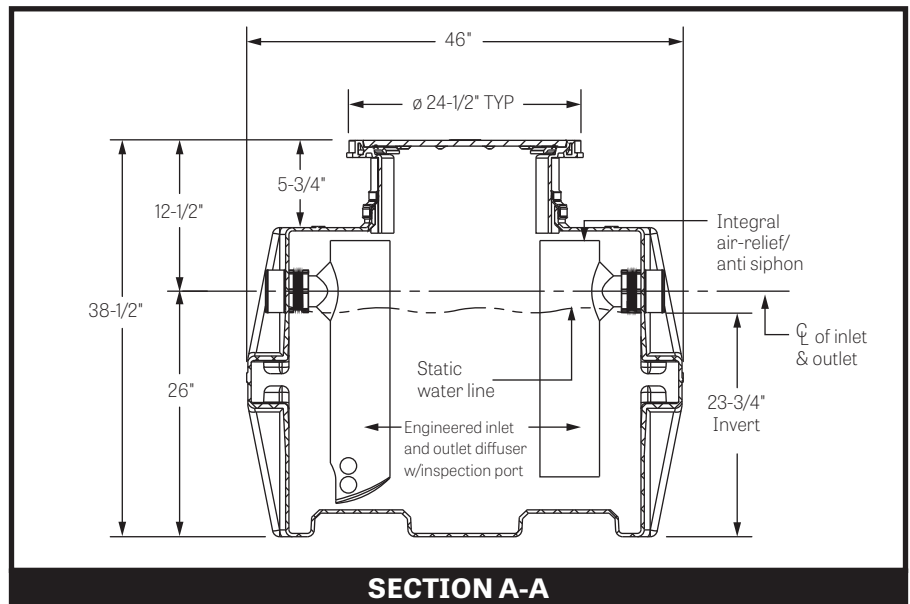
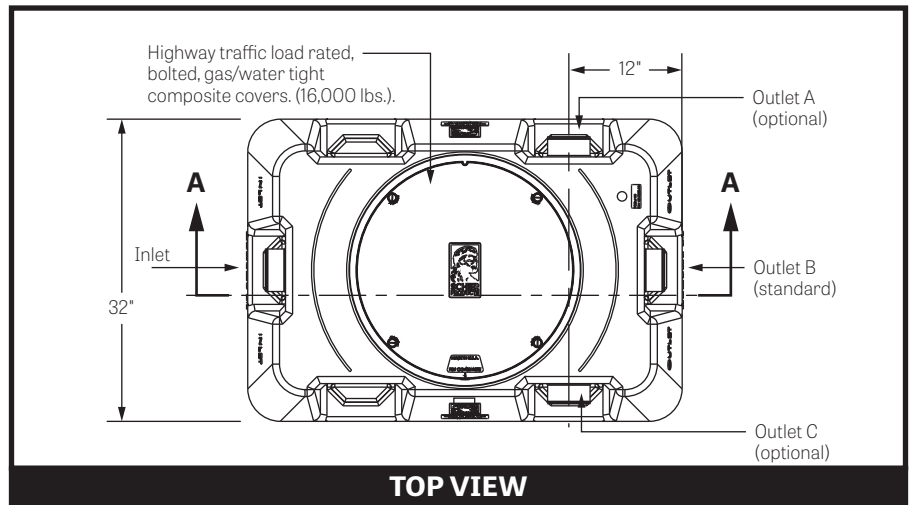
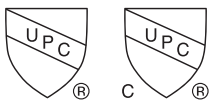

SCHIER
LIFETIME GUARANTEED
GREASE INTERCEPTORS

MODEL NUMBER:
GB-75

DESCRIPTION: Polyethylene Grease Interceptor
75 GPM - 125 gallon capacity

PART #: 4045-001-XX

DWG BY: B. Karrer

DATE: 10/08/2015

REV: 4 10/13/2017

ECO:

INSTALLATION (1 of 2)

WARNING! DO NOT AIR TEST UNIT OR TELEGLIDE RISER SYSTEM! Doing so may result in property damage, personal injury or death.

LEAK/SEAL TESTING

Cap/plug all base unit plumbing connections and remove covers. **For base unit testing**, fill with water to just above the highest connection. **For riser system testing** (if required) fill with water to finished grade level. **CAUTION: Risers must be supported before filling with water to prevent tipping.** Inspect unit, connections and all gaskets and clamps (if applicable) for leaks. Check water level at specific time intervals per local code.

GENERAL INSTALLATION INSTRUCTIONS

Schier grease interceptors are manufactured with an internal flow control system. They do not require an external flow control system or air intake vent. Schier grease interceptors are not to be installed in any other manner except as shown. Consult local codes for separate trapping requirements, cleanout locations and additional installation instructions.

1. The **flow control plate is not installed** on this unit. When the unit is installed 13 feet or more below the fixtures being served, or a high flow/increased head pressure condition exists (causing a flow rate above 75 GPM), install the inlet diffuser flow control plate to maintain proper flow rate.
2. Set unit on level solid surface as close as possible to fixtures being served.
3. Connect outlet diffuser to the desired outlet (A,B,C). Unit is shipped with the outlet diffuser in location B and sealing caps on locations A and C.
4. Connect inlet and outlet drainage lines to unit. Mechanically couple pipe to unit. **Do not solvent weld.**
5. For units with cast iron cover, remove retainer clips prior to burial.

NOTE: Do not install below a hydrostatic slab.

BELOW GRADE INSTALLATION INSTRUCTIONS

EXCAVATION

1. Surrounding soil must be undisturbed soil or well compacted engineering fill.
2. Width and length of excavation shall be a minimum of 12" greater than the tank on all sides and depth shall be 6" deeper than tank bottom.
3. Set the tank level on a 6" deep layer of well-packed crushed aggregate material and connect waste piping per General Installation Instructions.

BACKFILL

1. Preparation of sub grade per geotech recommendations.
2. Stabilize and compact sub grade to 95% proctor.
3. Fill unit with water before backfilling to stabilize unit and prevent float-out during backfilling. Secure covers and risers (if necessary) to the unit.
4. Backfill evenly around tank using crushed aggregate (approximately 3/4" size rock or sand, with no fines), or flowable fill. **Do not compact backfill around unit.**

FINISHED CONCRETE SLAB

Slab must extend 18" minimum outside the unit footprint.

Pedestrian traffic or greenspace areas: 4" Thick reinforced concrete slab required.

Vehicular traffic areas: Minimum 8" Thick concrete slab with rebar required. Thickness of concrete around cover to be determined by specifying engineer. If traffic loading is required the concrete slab dimensions shown are for guideline purposes only. Concrete to be 28 day compressive strength to 4,000 PSI. Use NO. 4 rebar (ø 1/2") grade 60 steel per ASTM A615: connected with tie wire. Rebar to be 2-1/2" from edge of concrete and spaced in a 12" grid with 4" spacing around access openings.

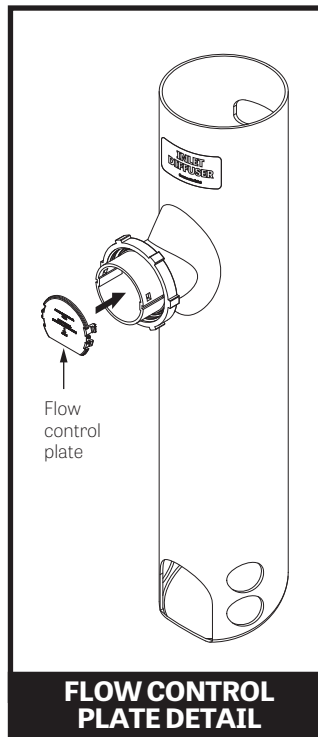

FLOW CONTROL PLATE DETAIL

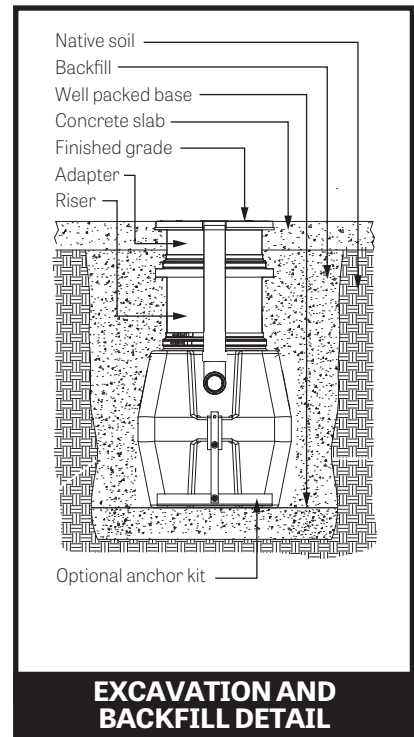

EXCAVATION AND BACKFILL DETAIL

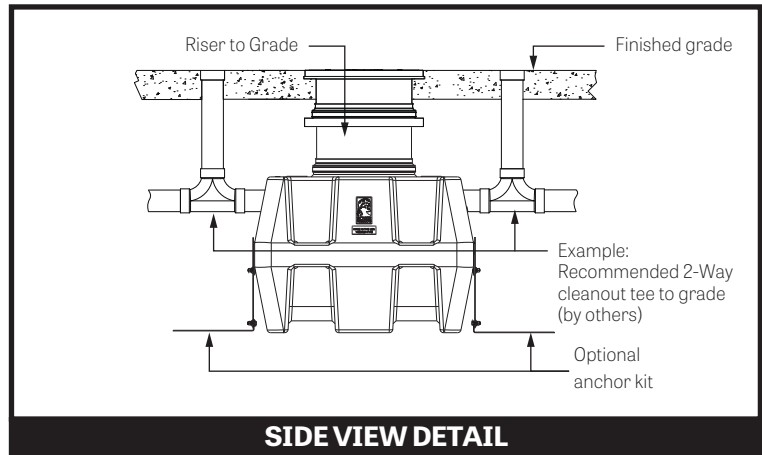

SIDE VIEW DETAIL

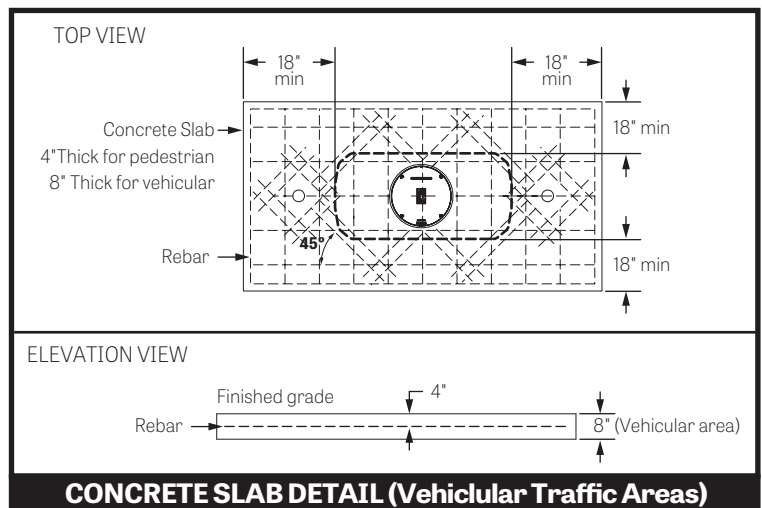

CONCRETE SLAB DETAIL (Vehicular Traffic Areas)



SCHIER
LIFETIME GUARANTEED
GREASE INTERCEPTORS

MODEL NUMBER:
GB-75

DESCRIPTION: Polyethylene Grease Interceptor
75 GPM - 125 gallon capacity

PART #: 4045-001-XX

DWG BY: B. Karrer

DATE: 10/08/2015

REV: 4 10/13/2017

ECO:

INSTALLATION (2 of 2)

TELEGLIDE RISER (24 SERIES) INSTALLATION GUIDELINES

Tools needed: 7/16" Nut driver tool/bit (included), marker (included), tape measure and drill with 1/2" chuck. Jigsaw, circular saw or reciprocating saw will be needed if risers need to be cut.

NOTE: To remove a component or adjust its position, the Upper Band Clamp needs to be loosened or removed using nut driver bit. Loosened clamps should be retightened to 5 - 8 ft lbs. of torque (same as a rubber no-hub coupling). **The Lower Band Clamp is factory set and should not be adjusted or removed.**

Riser Assembly Instructions/Steps

1. Set unit so the pipe connections line up with jobsite piping and measure riser height needed from top of cover to finished grade. See Table 1 to select risers needed.
2. Remove covers from adapters. Remove adapters from main unit. On a level surface, pre-assemble the risers and adapters, adjusting the components upwards or downwards to achieve the riser height needed. Make sure to maintain minimum and maximum insertion depths as shown in Figure 2. If components are too long, make a circular line around the sidewall with marker and cut with a power saw. The lowest cut line on the riser assembly will be 6" beyond the riser height needed to allow for ideal insertion depth (See Figure 1). An alignment mark should be drawn 2" beyond the riser height needed which will align with the top of the base unit gasket. **DO NOT** cut the alignment mark. The Adapters and risers should sit level with each other. Tighten upper clamps to keep riser/adaptor assembly from shifting. Make alignment marks on the sidewalls at the top of all riser gaskets to aid final assembly.
3. **IMPORTANT:** Before the next step, make sure both diffusers are installed inside the main unit at the appropriate locations. Check if there needs to be any flow control adjustment at the inlet diffuser (see general installation instructions).
4. Take apart riser assembly and clean all sidewalls and insides of gaskets to remove dust/debris. Install components into the main unit starting from the lowest riser and work your way up to finished grade. Ensure that riser will not interfere with diffuser, allow min. 1" clearance. Maintain minimum and maximum insertion depths for all components (see Figure 2). Tighten Upper Clamps to specified torque after correctly positioning components. Riser assembly may need to be supported during backfill.
5. If tilting of the adapter is required to be flush with grade, do so **AFTER** all clamps have been tightened with riser(s)/adaptor in a vertical and level position. Tilting is done using gasket flexibility. Schier recommends tilting only the adapter versus the entire riser assembly to make sure your riser height and proper tank access is maintained.
6. If riser height conditions change after completing above steps, there may be room for adjustment. As long as minimum and maximum insertion depths are maintained (see Figure 2), the adapters/risers can be adjusted/cut as many times as necessary. When riser system installation is complete, see Leak/Seal Testing procedure if required (p3 of 6).

ANCHOR KIT INSTALLATION

Stainless steel anchor kit is recommended for installation in high water table conditions to prevent float out. Necessity to be determined by specifying engineer. Hold down force achieved by backfill weight acting on Anchor Plate.

Slide Anchor Hook over tie down point on end wall and bolt to Anchor Strap. Bolt Anchor Strap to Anchor Plate using provided stainless steel hardware. If required, Anchor Plate may be bolted to concrete slab using provided holes.

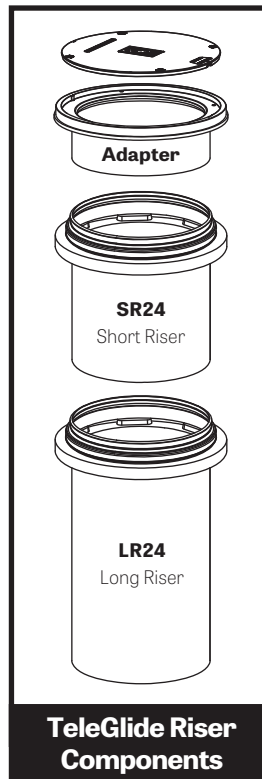

TeleGlide Riser Components

Table 1

Riser Height Needed	Risers Required
0 - 3-1/2"	None (use adapter)
5" - 23"	SR24
>23" - 38"	LR24
>38" - 43"	SR24 (x2)
>43" - 58"	SR24 + LR24
>58" - 72"	LR24 (x2)

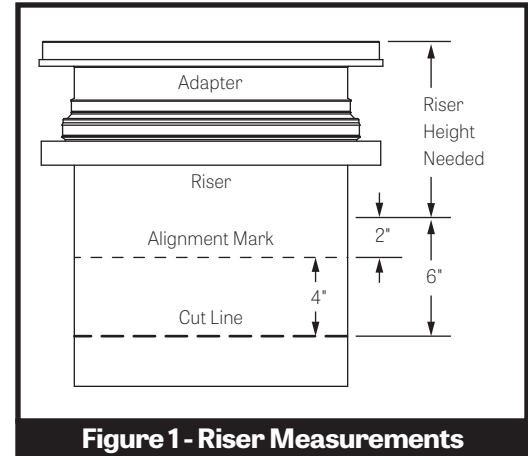

Figure 1 - Riser Measurements

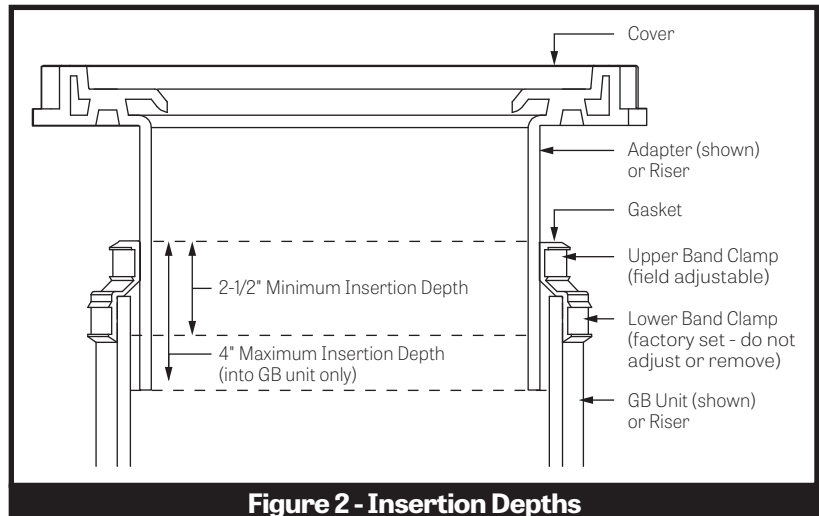
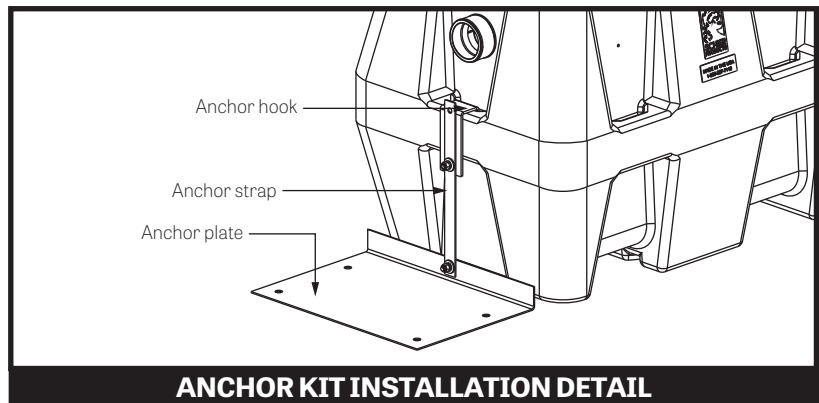

Figure 2 - Insertion Depths



ANCHOR KIT INSTALLATION DETAIL



SCHIER
LIFETIME GUARANTEED
GREASE INTERCEPTORS

MODEL NUMBER:
GB-75

DESCRIPTION: Polyethylene Grease Interceptor
75 GPM - 125 gallon capacity

PART #: 4045-001-XX

DWG BY: B. Karrer

DATE: 10/08/2015

REV: 4 10/13/2017

ECO:

APPLICATION SPECIFIC DETAILS

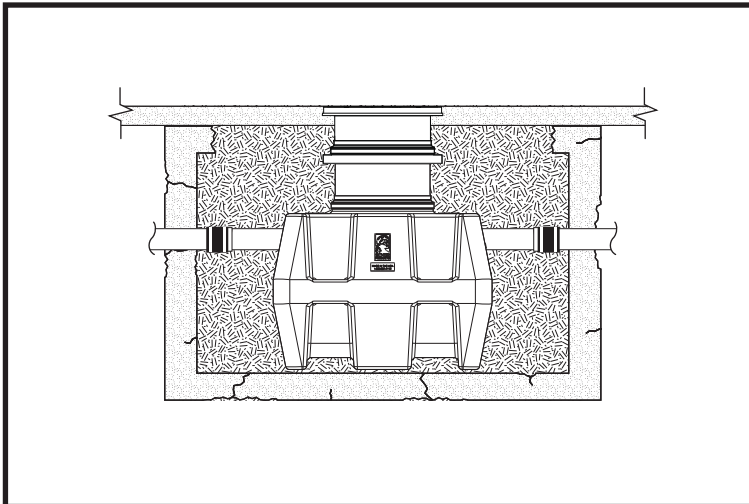

Inside a Corroded Concrete Unit

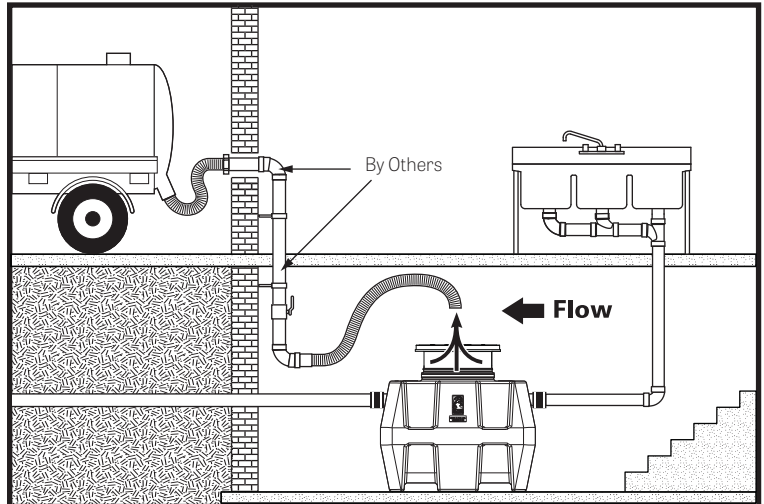

Basement Installation with Remote Pump-out

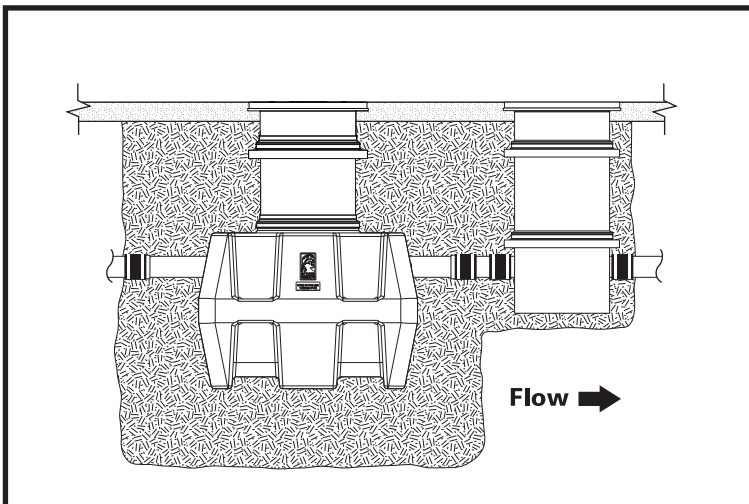

Installation with Sampling Port SV24-L4

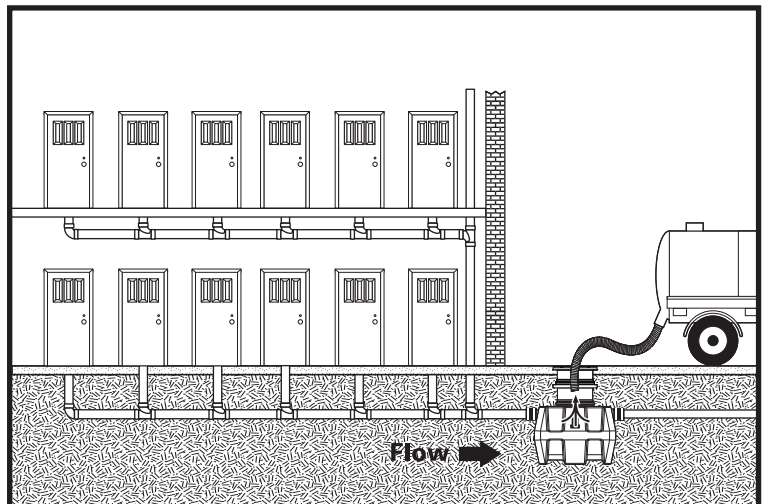

Serving an Apartment Complex

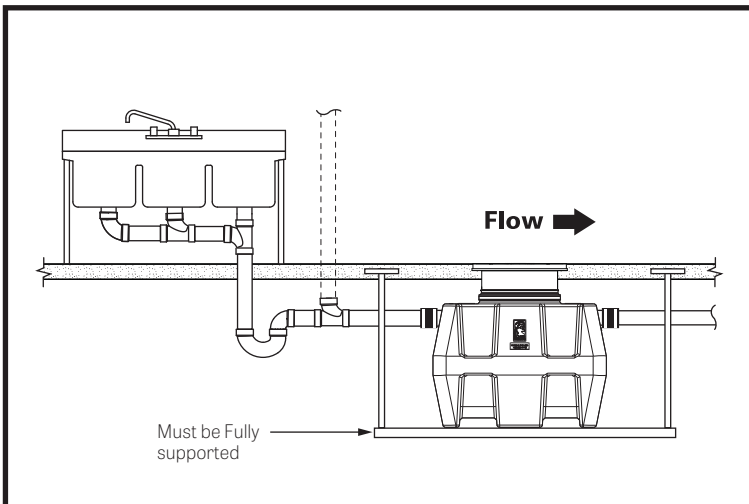

Recessed and Suspended

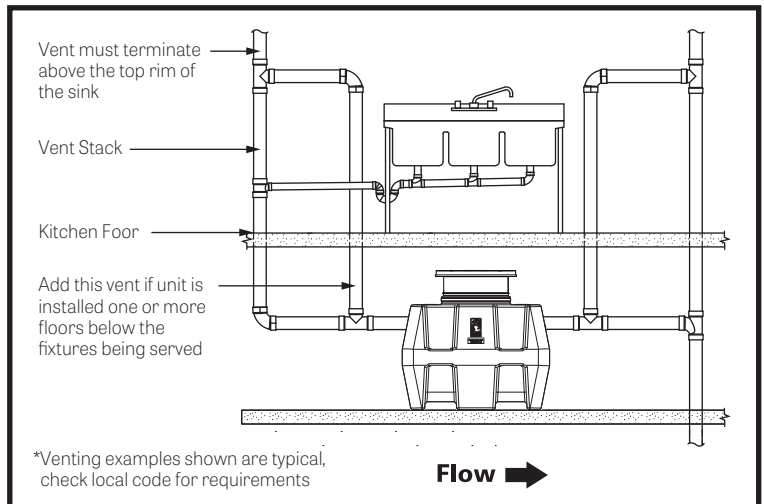

Additional Venting for Floor-Below Installations



SCHIER
LIFETIME GUARANTEED
GREASE INTERCEPTORS

MODEL NUMBER:
GB-75

DESCRIPTION: Polyethylene Grease Interceptor
75 GPM - 125 gallon capacity

PART #: 4045-001-XX

DWG BY: B. Karrer

DATE: 10/08/2015

REV: 4 10/13/2017

ECO: